



青岛创梦仪器有限公司

Qingdao Chuangmeng Instrument Co., Ltd.



API 中压滤失仪

API Filter Press

型号 Model: 1201/1231/ 1206

使用手册

Instruction Manual

版本. 1.0

Ver. 1.0

©版权所有青岛创梦仪器有限公司

© copyright all instrument Qingdao Chuangmeng Instrument Co., LTD

请你仔细阅读《使用手册》，正确掌握本产品的安装和使用方法。阅读后请将本《使用手册》妥善保管，以备今后进行检修和维护时使用。

Please read the Instruction Manual carefully, for correctly grasping the installation and using method of this product. Please keep properly this Instruction Manual after reading, for the usage during troubleshooting and maintenance in the future.

联系方式 Contact:

邮编 Zip code: 266100

网址 Website: www.qdcmyq.com

电话 Tel: 86-0532-66993768

传真 Fax: 86-0532-66993744

邮箱 E-mail: cmtech@sina.com

公司地址: 中国·青岛市市北区温州路 7 号

生产基地: 青岛市城阳区流亭街道兴海路 3 号

Address: No. 7 Wenzhou Road, City Northern District, Qingdao City, China

Production base: No. 3 Xinghai Road, Liuting Street, Chengyang District, Qingdao

I . 概述 Summary

API 中压滤失仪用于测量钻井液和水泥浆的滤失量和造壁性能。过滤速率是在室温和 100 psi（690 千帕）下，30 分钟通过单位过滤面积的滤液体积。30 分钟后沉积在滤纸上的滤饼（残留物）的厚度和一致性证明了壁的构建特性。

The API Filter Press is used to measure the filtrate loss and wall performance of drilling fluid and cement slurry. The filtration rate is at room temperature and 100 psi (690 kPa), and the filtrate volume per unit area is 30 minutes. The thickness and consistency of the filter cake (residue) deposited on filter paper 30 minutes later confirmed the construction characteristics of the wall.

II .规格 Specification model

			
型号 Model	1201	1231	1206
名称 Name	中压滤失仪 API Filter Press	中压滤失仪 API Filter Press	多联中压滤失仪 6 UnitAPI Filter Press
浆杯 Slurry cup	1	1	6
有效滤失面积 Availability filtration area	45.8cm ² (7.1 in ²)	45.8cm ² (7.1 in ²)	45.8cm ² (7.1 in ²)
工作压力 Working pressure	0.69MPa (100psi)	0.69MPa (100psi)	0.69MPa (100psi)
浆杯容量 Volume of slurry cup	350ml	350ml	350ml

III.气源 Air supply

中压滤失仪的压力源包括：氮气瓶、二氧化碳气弹、手动气泵。

The pressure source of FilterPress includes: Nitrogen cylinder, CO₂Cartridges and hand air pump.

3.1 氮气瓶 Nitrogen cylinder

1)将减压阀调整螺钉退回到关闭位置，打开氮气瓶上的压力阀。入口压力表显示氮气瓶压力。确保入口压力大于 100 psi±5 psi（690 kPa±35 kPa）。

2)连接好氮气瓶调节器和浆杯之间的软管，紧固所有的配件，关闭安全阀。

3)拧入减压阀调节螺钉，将 100 psi±5 psi（690 kPa±35 kPa）压力施加到浆杯。

开始计时 30 分钟。

1)Return the adjusting screw of the pressure relief valve to the closed position and open the pressure valve on the nitrogen cylinder. The entrance pressure gauge shows the pressure of the nitrogen cylinder. Ensure inlet pressure greater than 100 psi + 5 psi (690 kPa + 35 kPa).

2)Connect the hose between the nitrogen cylinder regulator and the slurry cup, tighten all the fittings and close the safety valve.

3)Screw the pressure relief valve regulating screw and apply 100 psi + 5 psi (690 kPa + 35 kPa) pressure to the slurry cup.

Start the time for 30 minutes.

3.2 二氧化碳气弹 CO₂Cartridges

1)从 CO₂ 压力组件上拆下加压管并插入一个新的 CO₂ 气弹。

2)关闭安全放气阀，减压阀调节螺钉退回关闭位置。然后拧紧加压管直到感觉到与穿刺针接触。

3)再次转动支架，大约 1/4 转。穿刺针刺穿气弹，并且保持密封状态。

4)拧入减压阀调节螺钉，将 100 psi±5 psi（690 kPa±35 kPa）压力施加到浆杯。

开始计时 30 分钟。

1)Remove the pressure pipe from the CO₂ pressure assembly and insert a new CO₂Cartridges.

2)Close the safety vent valve and the regulating screw of the pressure relief valve is

returned to the closed position. Then tighten the pressurized tube until you feel the contact with the puncture needle.

3) Turn the bracket again, about 1/4 turn. Puncture piercing the bomb and keep it sealed.

4) Screw the pressure relief valve regulating screw and apply 100 psi + 5 psi (690 kPa + 35 kPa) pressure to the slurry cup.

Start the time for 30 minutes.



3.3 手动气泵 Hand air pump

1) 将手动气泵软管与中压滤失仪连接，手动加压使手动泵气缸的压力压力大于 100 psi ± 5 psi (690 kPa ± 35 kPa)。

2) 关闭安全放气阀，减压阀调节螺钉退回关闭位置。

3) 拧入减压阀调节螺钉，将 100 psi ± 5 psi (690 kPa ± 35 kPa) 压力施加到浆杯。

开始计时 30 分钟。

1) Hand air pump hose is connected with the Filter Press. Manual pressure makes the pressure of Hand air pump greater than 100 psi + 5 psi (690 kPa + 35 kPa).

2) Close the safety vent valve and return the adjusting screw of the pressure relief valve to the closed position.

3) Screw the pressure relief valve regulating screw and apply 100 psi + 5 psi (690 kPa + 35 kPa) pressure to the slurry cup.

Start the time for 30 minutes.



IV.仪器的操作 Operation:

- 1)检查浆杯各部件，确保滤网清洁，密封圈未变形或损坏。
- 2)取出仪器支架，检查支架上的钻井液杯顶盖内是否放入橡胶圈，将仪器放平。
- 3)SD6A 型六联滤失仪，关闭针阀和所有浮动阀芯

- 1) Check the components of the slurry cup to ensure that the filter screen is clean, and the sealing ring is not deformed or damaged.
- 2)Take out the instrument bracket and check whether the rubber ring is placed in the top cover of the drilling fluid on the bracket, and put the instrument flat.
- 3)The Model SD6A Filter Press,Close the needle valve and all floating valve core.

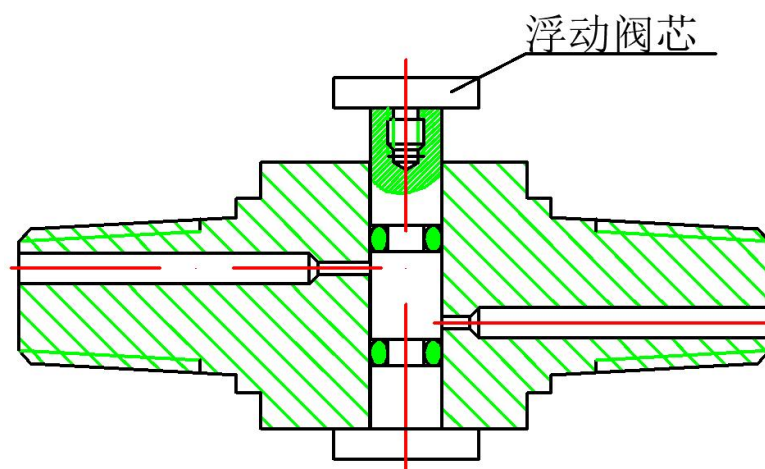

浮动阀芯 Floating valve core

4)ZNS-5A 型滤失仪，将气源输气管的连接螺母接在减压阀组件气源接头上旋紧，减压阀调节螺钉退回关闭位置。将打气筒充气,大于 100 psi±5 psi（690 kPa±35 kPa）。

4) The Model ZNS-5A Filter Press, Connect the connecting nut of the gas source pipe to the air source connector of the pressure reducing valve assembly, and return the adjusting screw of the pressure relief valve to the closed position. Inflate the handle pump, more than 100 psi ±5 psi (690 kPa±35 kPa) .

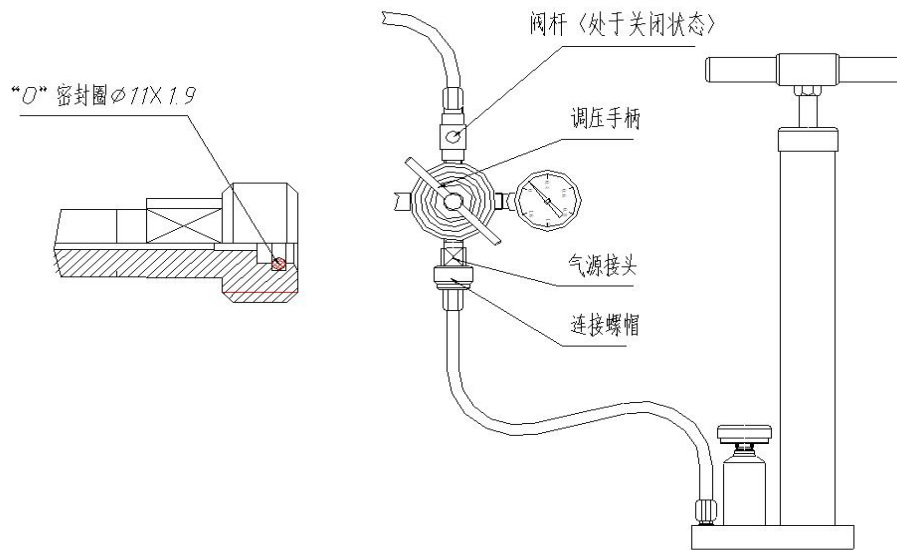

1201 滤失仪操作示意图

Operation schematic diagram of the Model ZNS-5A Filter Press

5)对 SD6A 型六联滤失仪，使放气阀处于关闭状态。将减压器安装于气瓶上拧紧螺母。减压阀调节螺钉退回关闭位置。打开气瓶气源手柄，调整减压器调压手柄，使减压器压力大于 100 psi±5 psi（690 kPa±35 kPa）。

5)The Model SD6A Filter Press, Make the vent valve close. Install the pressure reducer on the cylinder and tighten the nut. Return the adjusting screw of the pressure relief valve to the closed position. Open the gas source handle of the cylinder and adjust the pressure regulator handle of the pressure reducer so that the pressure of the pressure reducer is greater than 100 psi + 5 psi (690 kPa + 35 kPa).

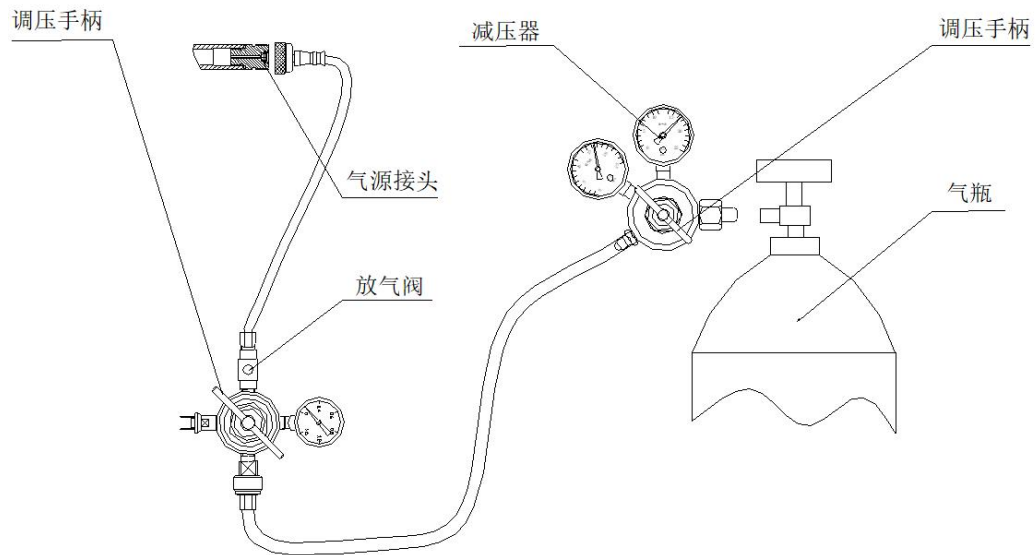

六联滤失仪操作示意图

Operation schematic diagram of the Model SD6A Filter Press

6)浆杯按以下顺序组装使用，将底盖内放入橡胶圈、滤网、滤纸、橡胶圈。浆杯杯体，杯体上有两圆柱销使其对准底盖两开口放入逆时针拧紧。将一定量的约（350ml）钻井液注入浆杯内至刻线。

7)将注入钻井液的浆杯放于支架上，顺时针方向旋转手柄或手柄，使顶盖和浆杯垂直方向压合密封。

8)将干燥的量筒放在排出管下面的量筒座上，用来接收滤液。

9)顺时针方向旋转减压阀调节螺钉，将压力调至 0.69MPa（100psi）。

10)打开减压阀浮动阀芯，压力进入浆杯实验开始，记录滤失时间。

6)The slurry cups are assembled in the following order, and rubber rings, filter screens, filter paper and rubber rings are arranged in the bottom cover. The cup body is provided with two cylindrical pins on the cup body for aligning the two opening of the bottom cover and putting it into a counterclockwise tightening. A certain amount of (350ml) drilling fluid is injected into the slurry cup to the reticle.

7)Put the slurry cup of the drilling fluid on the support and rotate the handle or handle in a clockwise direction, so that the top cover and the slurry cup are pressed and sealed vertically.

8) Put the dryness measuring cylinder on the measuring cylinder seat below the discharge pipe to receive the filtrate.

9) Turn the the adjusting screw of the pressure relief valve on the clockwise direction and adjust the pressure to 0.69MPa (100psi).

10) Open the floating valve core of the pressure relief valve, pressure enters the slurry cup experiment, record the filtration time.

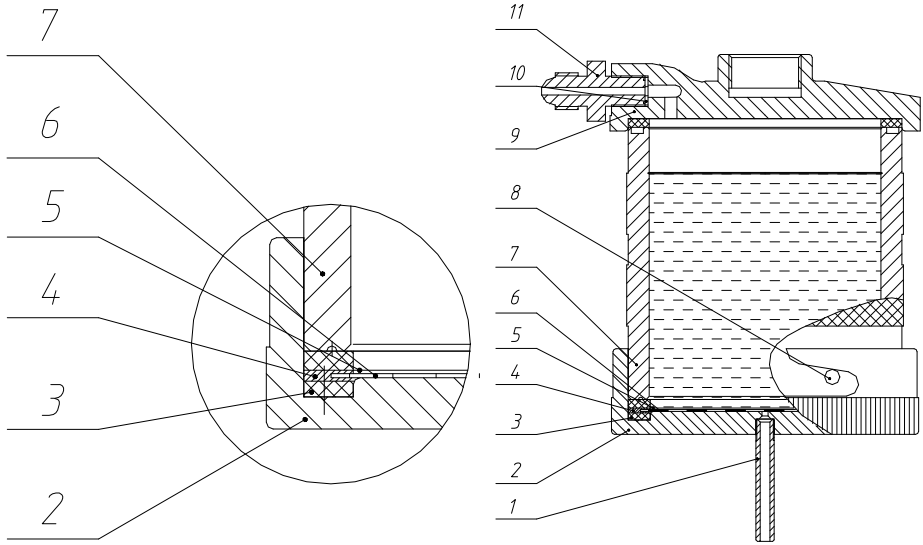

钻井液杯操作示意图

Schematic diagram of drilling fluid cup operation

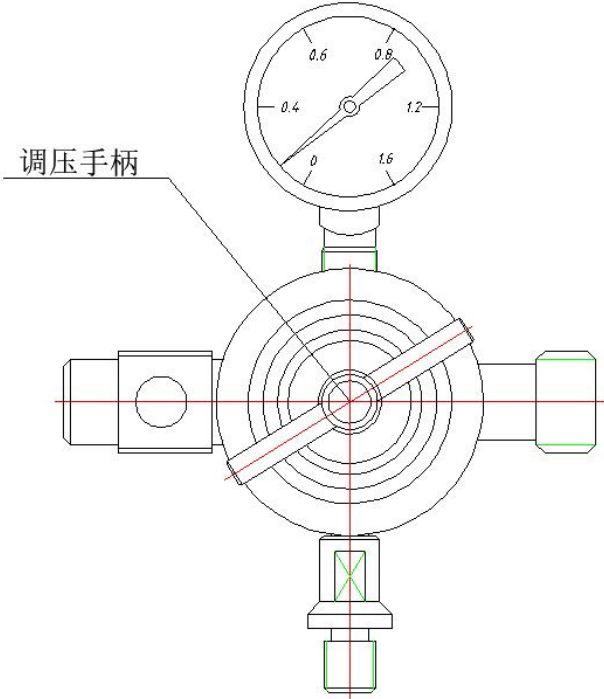

减压阀操作示意图

Operation diagram of pressure relief valve

11)对于 SD6A 型六联滤失仪，再打开试验对应浮动阀芯，压力进入浆杯实验开始，记录滤失时间。

12)以毫升为单位记录滤液的体积（精确到 0.1 毫升）并作为 API 滤失量，同时记录钻井液样品的初始温度℃（°F），保留滤液用作化学分析。

13)实验完毕，关闭气源，将浮动阀芯关闭，（排出浆杯余气）。

14)在确定杯内压力全部放掉的前提下，逆时针方向旋转手柄，从支架上取下钻井液杯，倒掉钻井液，取下滤饼冲洗干净。

15)将仪器清洗干净，保管。

注意；严禁使用氧气。

拆卸浆杯和气源之前必须放掉余气。

11)The Model SD6A Filter Press,Then open the test to correspond to the floating valve core, the pressure enters the pulp cup experiment, and record the filtration time.

12)The volume of the filtrate was recorded in milliliter (accurate to 0.1 milliliters) and used as the API filter loss, and the initial temperature of the drilling fluid was recorded at the same time, and the retained filtrate was used as a chemical analysis.

13)After the experiment, close the gas source and close the floating valve core.(expelled slurry cup's residual gas)

14)When the pressure in the cup is all released, the handle is rotated in anti-clockwise direction, the drilling fluid cup is removed from the bracket, the drilling fluid is dropped and the filter cake is washed out.

15) Clean the instrument and keep it.

Note: The use of oxygen(O₂) is strictly prohibited.

The residual gas must be removed before removing the slurry cup and gas source.

青岛创梦仪器有限公司 装箱单

Qingdao Chuangmeng Instrument Co., Ltd.Packing list

生产企业：青岛创梦仪器有限公司

Manufacturing enterprise: Qingdao Chuangmeng Instrument Co.,Ltd.

生产地址：青岛市城阳区流亭街道兴海路 3 号

Production address:No. 3 Xinghai Road, Liuting Street, Chengyang District, Qingdao

主机型号:中压滤失仪

Model of the main motor:API Filter Press

出厂编号：

Manufacturing No:

序号 NO	编号	名称及规格 Name and specification	单位	数量 Quantity	备注 Remarks
1		主体 Main body	台	1	
2		浆杯（通用） Slurry cup	只		
3		减压阀 Pressure relief valve	套	1	
4		打气筒（1201） Handle pump	只	1	
5		气弹筒（1231 型） Cartridges cylinder	只	1	
6		“O”型圈（ $\phi 6 \times 1.8$ ） "O"- ring（ $\phi 6 \times 1.8$ ）	只	10	
7		“O”型圈（ $\phi 11 \times 1.8$ ） "O"- ring（ $\phi 11 \times 1.8$ ）	只	5	
8		胶垫 cushion	只		
9		PH 试纸 PH test paper	本	3	
10		987 滤纸（ $\phi 90$ ） 987Filter paper（ $\phi 90$ ）	盒	1	
11		量筒（25ml） Graduated Cylinder	只		
12		塑料量杯（500ml） Plastic counting cup	只	1	
13		使用手册 Instruction Manual	份	1	
14		合格证 Certificate	份	1	